

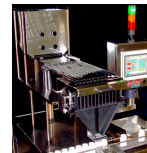

## Packaging Solutions



# Modular Packaging Systems



**the Most INNOVATIVE**



**the Most INTEGRATED**



**the Most INVALUABLE**



Innovative

Integrated

Invaluable



*Modular Packaging provides packaging solutions and component integration to the pharmaceutical and nutraceutical industries.*



Innovative

Integrated

Invaluable



*Modular Packaging manufactures a full line of Tablet Filling Equipment*

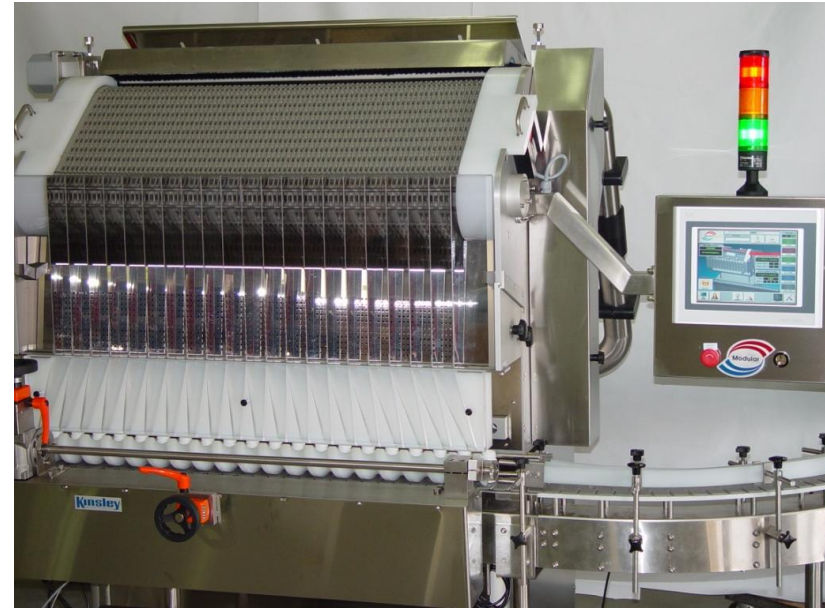
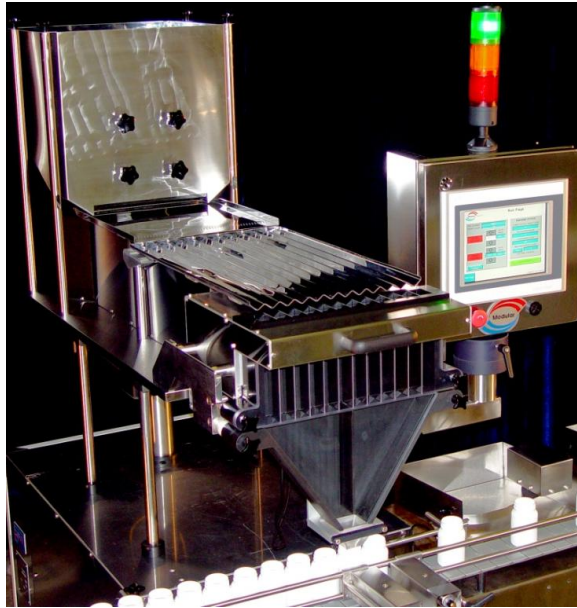

Innovative

Integrated

Invaluable



*Modular Packaging designs its equipment using 3D CAD Software*

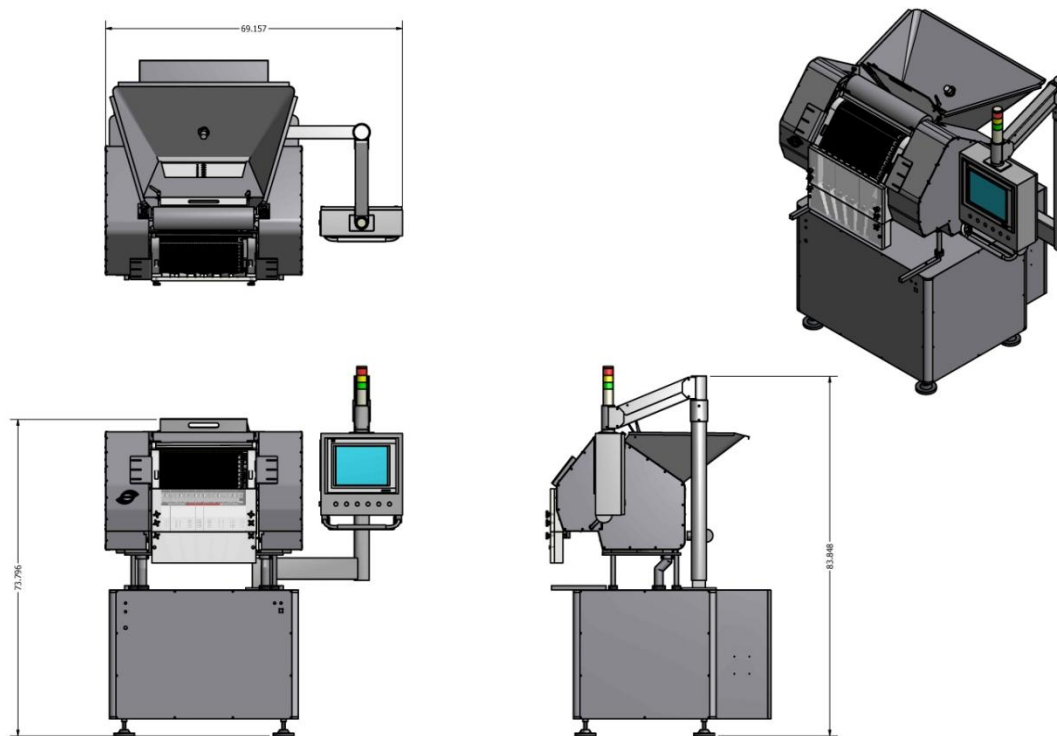

# Advanced Control Packages



- Graphic Driven Touch Screen
- Various Levels of Password Protection
- Easy Integration with other components including vision and serialization
- Remote monitoring

Innovative

Integrated

Invaluable



*Modular Packaging manufacturers container handling components*

- Sanitary Conveyors –straight and 90 degree curve sections
- Unscrambling, Surge and Accumulation Tables
- 90 degree turn disks
- Spacing wheels
- Timing screw drives
- Reject stations
- Pack off tables
- Drives, Rails, Crossovers, and other accessories
- Utilities Distribution (Power and Air) Troughs and Control Systems

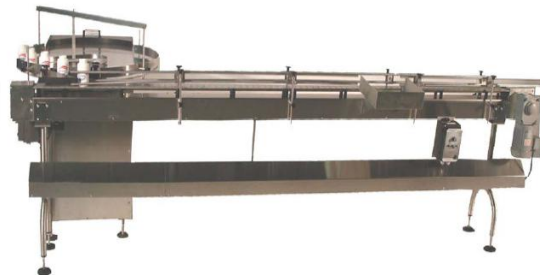

Innovative

Integrated

Invaluable



*Modular Packaging integrates “world class” components to complete its packaging lines.*

- Unscramblers and Air Rinsing Systems
- Marking and Coding Systems
- Literature placement systems- topserters and outserters
- Desiccant Inserters (canister and pouch systems)
- Cappers
- Induction Sealers
- Metal Detectors
- Labelers
- Vision Systems
- End of the Line : Shrink Bundlers / Cartoners / Case Packers / Palletizers





## *Tablet Filling Equipment*

- MC 2 Table Top Counter
- EC 12 Electronic Counter
- VC 12 Economy Tablet Counter
- MPS 48-10-A Slat Filler
- MPS 60 Large Format Filler
- MPS 72 High Speed Filler

Innovative

Integrated

Invaluable



## *MC2 - Table Top Electronic Counter*

### Standard Features:

- UP TO 8 BOTTLES BPM (BASED ON 100 COUNT OF ¼" ROUND TABLET)
- ACCURATE COUNTS
- 2 COUNTING LANES
- PRODUCT FEED CONTROL
- CGMP DESIGN
- LIMITED CONTACT PARTS TO CLEAN
- SIMPLE SET UP AND CHANGE OVER
- FULLY REMOVABLE CONTACT PARTS (WITH OUT TOOLS)
- FUNNEL DELIVERY SYSTEM
- BOTTLE LOADING TRAY
- VACUUM SYSTEM
- DIGITAL DISPLAY AND CONTROL PANEL



Innovative

Integrated

Invaluable



## *EC12 - Electronic Counter*

### Standard Features:

- UP TO 55 BPM (BASED ON 100 COUNT OF ¼" ROUND TABLET)
- 100 % ACCURATE COUNTS
- TWO TRAY SYSTEM (12 COUNTING LANES)
- PRODUCT DISCRIMINATION / SELF TEACH FUNCTION
- REJECTION STATION
- SINGLE PIECE SENSOR AND SHUTTER ASSEMBLY
- MOTORIZED HEIGHT ADJUSTMENT
- PNEUMATICALLY CONTROLLED QUICK RELEASE FEEDER TRAYS
- MINIMAL CONTACT PARTS TO CLEAN /CGMP DESIGN
- RECIPE STORAGE (ALPHANUMERIC)
- LARGE USER-FRIENDLY TOUCH SCREEN INTERFACE (COLOR)
- FRONT AND REAR VACUUM MANIFOLDS / NOZZLE VIBRATOR
- BOTTLE DETECTION SENSORS

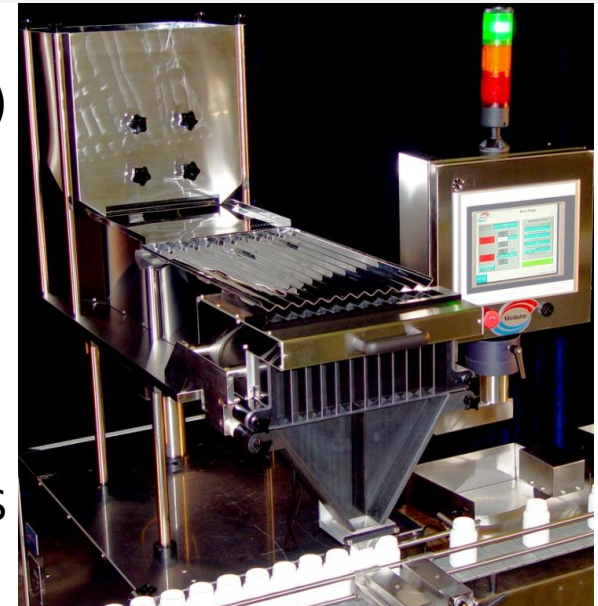

Innovative

Integrated

Invaluable



## VC 12 - TABLET COUNTING MACHINE

“Lowest cost, high-speed machine on the market”

Standard Features:

- UP TO 45 BPM (BASED ON 100 COUNT OF ¼” ROUND TABLET)
- ACCURATE COUNTS
- TWO TRAY SYSTEM (12 COUNTING LANES)
- MOTORIZED HEIGHT ADJUSTMENT
- PNEUMATICALLY CONTROLLED FEEDER TRAYS
- MINIMAL CONTACT PARTS TO CLEAN
- CGMP DESIGN
- RECIPE STORAGE
- USER-FRIENDLY TOUCH SCREEN INTERFACE (COLOR)
- FRONT AND REAR VACUUM MANIFOLDS
- BOTTLE DETECTION SENSORS



Innovative

Integrated

Invaluable



## *48-10-A - Servo Controlled Slat Filler*



- 48 Slat Design minimizes change part costs
- Servo Controlled for accurate
- Touch Screen Integrated Controller
- “Workhorse” Design

Innovative

Integrated

Invaluable



## *48-10-A - Servo Controlled Slat Filler*

### STANDARD FEATURES

- UP TO 140 BPM (BASED ON 100 COUNT 20 DROP SLAT)
- 100% ACCURACY
- 10 DROP OR 5 DROP FUNNELS (Bottle Diameter Determined)
- cGMP DESIGN / TOOL-LESS REMOVAL PRODUCT CONTACT PART ASSEMBLIES
- HOPPER LEVEL PROXIMITY SENSOR / VARIABLE SPEED TOP BRUSH (AC MOTOR) / MULTIPLE DUST EXTRACTION POINTS
- STATIC ELIMINATOR
- BOTTLE COUNT VERIFICATION – IN and OUT
- BOTLLE INFEED AND BACKUP DETECTION



Innovative

Integrated

Invaluable



## *MPS Bottle Wrap Labeler*

### STANDARD FEATURES

- UP TO 200 BPM
- Lot and Expiration Date Coding on the Web with Camera Verification
- Large Format Touch Screen Controls

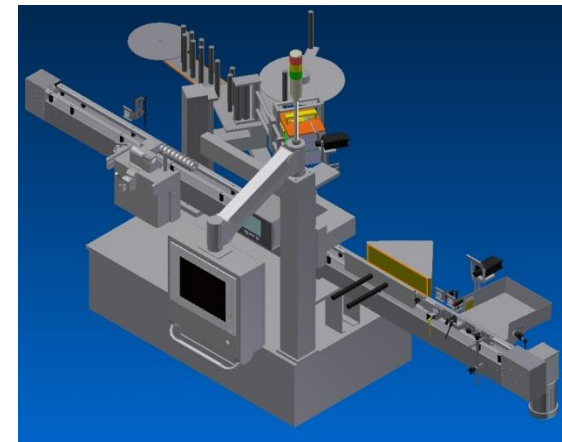

# Central Monitoring System

- All of the visualization, controller and drive modules in the entire system can be accessed using one interface
- Components can be replaced easily without requiring expensive specialized personnel or extra resources
- Uniform hardware across machine line reduce number of components used.
- Diagnostic tools used for remote maintenance. Fast detection and correction of errors.

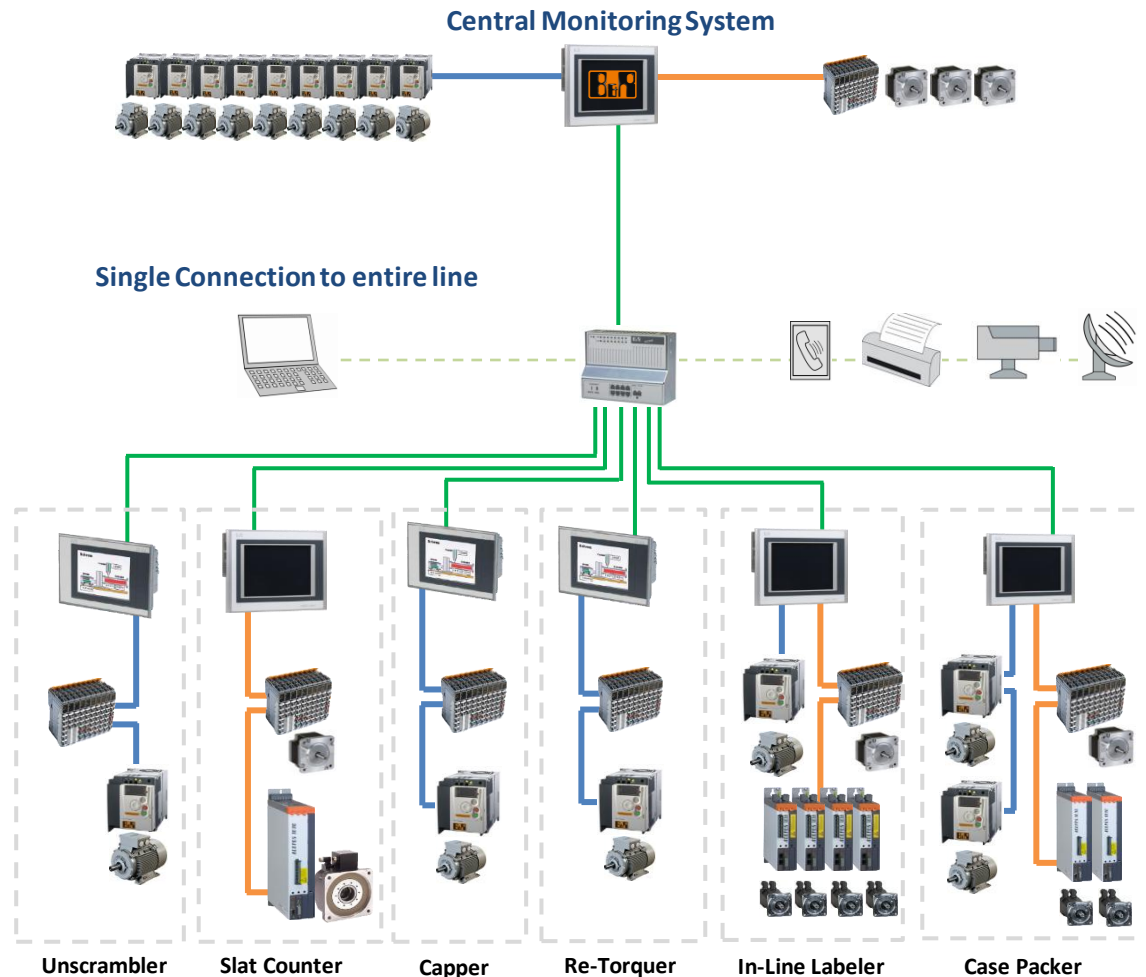

Innovative

Integrated

Invaluable



*FOR MORE INFORMATION*



[www.modularpackaging.com](http://www.modularpackaging.com)

Phone (973)970-9393 / Fax (973) 970-9388

[customerservice@modularpackaging.com](mailto:customerservice@modularpackaging.com)

6 Aspen Dr. Randolph NJ 07869